

PRODUCT BROCHURE

MAX300-LG

Laboratory Gas Analyzer



Fast Response

Process Control

**Stable
Measurement**

- Real-Time Gas Analysis
- Catalysis Monitoring
- Trace Gas Detection
- Environmental Research
- Multipoint Process Control

Introducing the MAX300-LG High Performance Quantitative Gas Analyzer

The MAX300-LG™ brings an unmatched combination of speed, sensitivity and precision to continuous, quantitative gas analysis.

Based on cutting-edge quadrupole mass spectrometer technology, the MAX300-LG has the dynamic range to measure component concentrations from 100% down to the low parts per trillion (ppt). It provides a full-composition update every few seconds to measure changes in dynamic chemical processes.

The MAX300-LG has the flexibility and rugged stability necessary for real-time quantitative gas analysis in applications as diverse as catalysis R&D, ambient air monitoring, and bioreactor process control.

The mass spectrometer uses an ionizer to break sample molecules into charged fragment ions that are then separated based on their mass-to-charge ratio as they move through the electric fields generated by the quadrupole mass filter. The ions register a current at the detector, creating a set of peaks called a mass spectrum. Each compound has a unique spectrum, making mass spectrometry a highly selective, flexible technique.

The MAX300's industry-leading 19mm quadrupole mass filter, combined with state of the art electronics, provides the user with an impressive list of **Extrel Advantages:**

- Near-zero mass scale drift for outstanding measurement precision and stability
- Uniform resolution across the entire mass range for ultra-high sensitivity to all compounds
- Extreme resistance to corrosion and contamination for long-term, continuous, low-maintenance operation
- Performance specifications that exceed those common to other mass spectrometers and process technologies

Laboratory Gas Analyzer Features

- Measures any gas or vapor sample
- Complete quantitative sample composition
- Real-time analysis of the input and effluent streams reveals what is happening in the reaction
- Fast response: reveals changes to sample concentration in <300ms
- Automated online analysis and data delivery
- Sample selector options for up to 61+ sample streams
- Useful at every stage of process development - Laboratory, Pilot, Production



MAX300-LG Laboratory Gas Analyzer

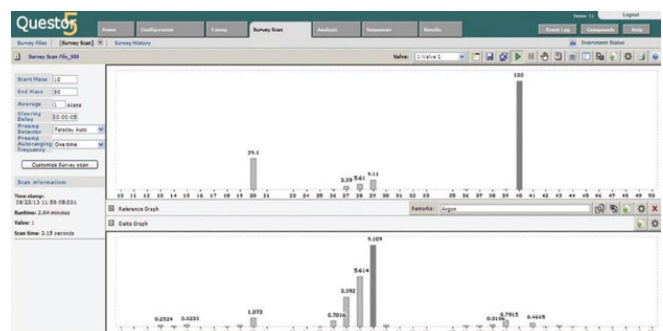
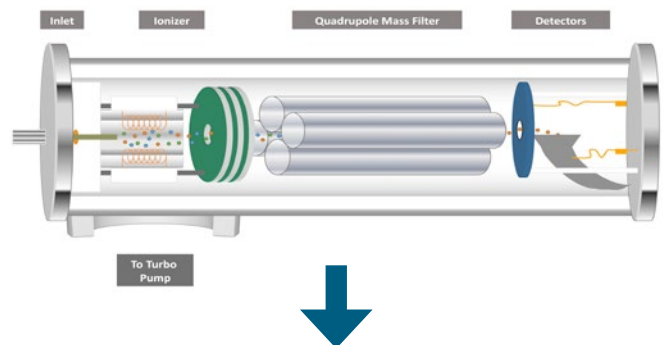

Sensitivity, Precision, Flexibility

Simply use the software to select the gases to measure, or the mass range to scan, and the MAX300-LG is configured to monitor a new reaction or process.

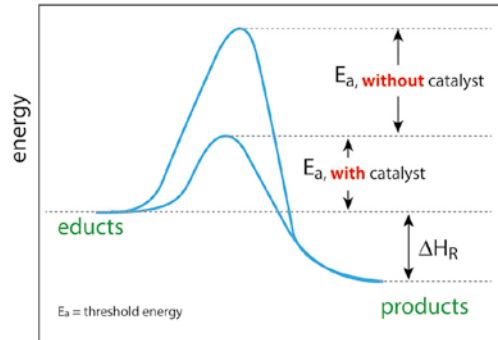

Gas and Vapor Analysis

- Catalysis
- Reaction Monitoring and Kinetics
- TPD/TPR/TPO
- Combustion Studies
- Process Development
- Vapor Deposition



Gas Phase Synthesis

- Pilot Scale Process Control
- Evolved Gas Analysis
- Bioreactor Monitoring
- Organic Chemistry
- Breath Analysis



Environmental Analysis

- Fuel Cell Studies
- Alternative Fuels
- Gasification
- Air Monitoring



Pure Gas Analysis

- Trace Contamination Pharmaceutical
- Solvents Semiconductor
- Manufacturing Scrubber Efficiency
- Food and Beverage Gas
- Gas Mixing

We're Ready for Your Sample

Successful gas analysis begins with the right sample interface. Decades of collaboration with research and industry have generated a host of inlet configurations to protect your sample in transit to the detector, and ensure you are getting the data you need out of your process.

Sample Inlet Configurations:

- Gate valves for samples with a fixed pressure < 5 Torr
- Capillaries for samples with a fixed pressure > 5 Torr
- Automated Multiport stream selection
 - 4, 16, 31, 46, 60+
- Differentially pumped inlets for fast clearing
- Automated pressure control for variable pressure samples
- Heated inlets for various temperatures and pressures

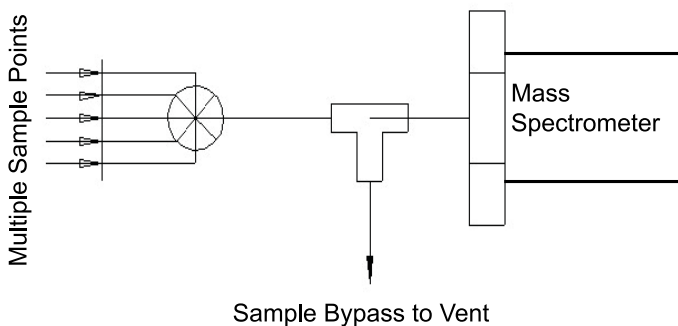

Example 1. Multiport sample selector diagram

Component	% Molecular Concentration	Precision % Absolute
Hydrogen	16.5	0.006
Methane	77.9	0.007
Nitrogen	0.38	0.002
Propane	0.9	0.001
Ethane	2.35	0.002
N-pentane	0.16	0.001
Isobutane	0.27	0.001
Carbon dioxide	0.95	0.001
Isopentane	0.15	0.001
N-Butane	0.45	0.001
Hexane	0.01	0.0002
Hydrogen sulfide	0.001	0.00001

The MAX300-LG performs a full-composition, continuous analysis that reveals ongoing changes within a process or reactor. It measures trace components and %-level gases in a single scan and provides high-precision updates every few seconds. Long-term stability without the need for recalibration or operator intervention ensure day-to-day usability for 24-7 monitoring, or repeatable sample runs.

Questor5 Quantitation Software Features

- Number of components: Unlimited
- Number of analysis routines: Unlimited
- Automatic removal of spectral overlap
- Data recorded as % or ppm
- Manual or automated calibration
- Number of user configurable data tags and alarms: Unlimited
- 21 CFR Part 11 compliant
- Security levels: Administrator, User, Viewer
- Comprehensive spectral library included
 - NIST MS database and spectrum matching software upgrade, optional
- Analysis can be triggered by external devices
- External communications
 - Ethernet, Modbus serial, digital I/O, analog I/O, OPC

System Specifications

Detectable compounds:

Any gas or vapor sample

Detection range:

- Faraday detector: 100% – 5 ppm
- Electron multiplier: 100% – 5 ppb*
- Membrane inlet: 100% – 10 ppt*

Analysis rate:

- 0.005 – 16 seconds per component
- User selectable

Number of components: Unlimited

Number of analysis routines: Unlimited

Number of user configurable data tags:
Unlimited

Precision: <0.05% RSD over 24 hours**

Stability: <0.5% RSD over 30 days**

Ionization energy control for reduced fragmentation

Automated detector switching within a single scan

Filaments: Two, one active and one spare with automatic switchover

Analyzer maintenance: 1-3 years†

Roughing pump: 6-12 months†

Manual or fully automated calibration and validation: 3-12 month calibration intervals

Mass range options: 1-250, 300, 500 amu

19 mm High-transmission quadrupole filter

* Matrix dependent. Documented on trace air components and benzene.

** Based on the analysis of 1% argon, scan speed 1 second per analysis with no recalibration or intervention of any kind.

† Application dependent.

Low Maintenance, Easy to Use

The Questor5™ control software that drives the MAX300-LG provides both quantitative and qualitative analysis modes, and the ability to build an unlimited number of fully-automated analysis routines. The intuitive web-based interface allows the user to check instrument status, review data, or run an acquisition from anywhere on the laboratory network, while maintaining government and industry security standards for login and electronic record keeping.

The MAX300-LG is a 24-7 online gas analyzer with a documented uptime >99%.

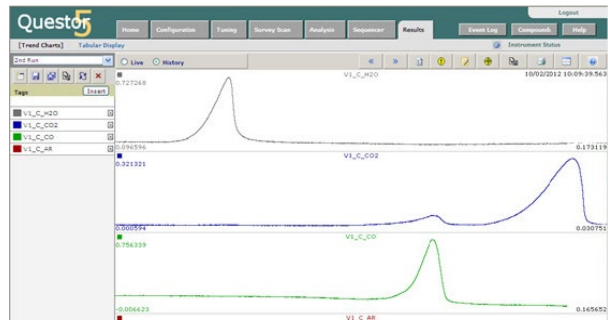

Simultaneously trend high precision measurements of bulk components and ppm-level contaminants with the easy-to-use Questor5 control software.



Extrel's 19 mm quadrupole next to a common 6 mm filter. The larger device provides greater ion transmission for unparalleled sensitivity and signal stability.



The MAX300 disposable, plug-and-play ionizer eliminates the cleaning requirement, and includes dual filaments, one active and one spare.

MAX300-LG System Specifications

Power Supply Options:

- 110 vAC +/- 10% vAC 50/60 hz, 10 Amp Circuit
- 230 vAC +/- 10% vAC 50/60 hz, 10 Amp Circuit

Power Consumption:

- Nominal 700 Watts

Weight:

- Approximately 165 lbs (75 kg)
- Optional cart: 40 lbs (18 kg)

Ambient Requirements:

- 55°F to 80°F (13°C to 27°C)
- Area Classification: General Purpose

Relative Humidity:

- 0-90% non-condensing

Data System and Communications:

- System control interface options: Ethernet or USB
- Login security levels: Administrator, User, Viewer
- External communications: Ethernet, Modbus serial, digital I/O, analog I/O, OPC

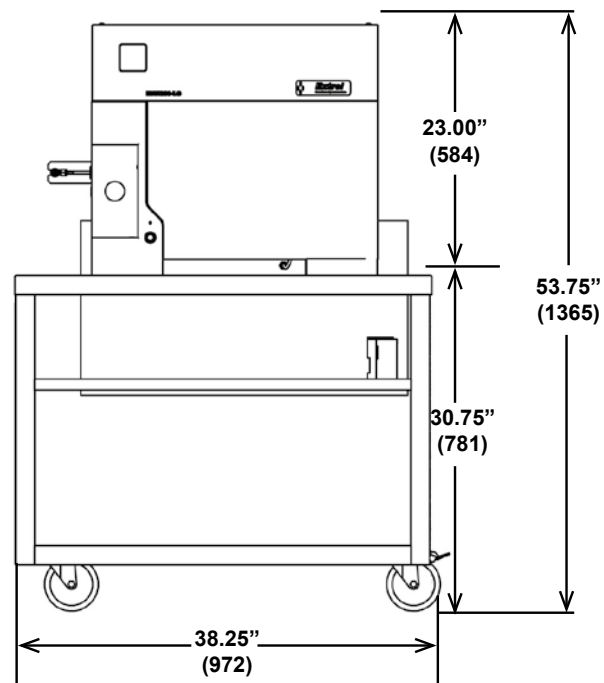

MAX300-LG enclosure with cart

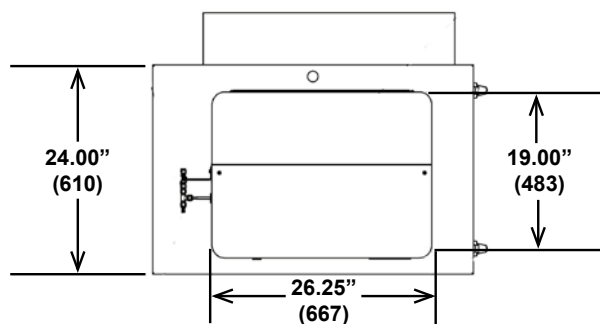

MAX300-LG enclosure with cart top view.

Dimensions shown in inches [cm]

Exceptional Worldwide Service and Support

For over 55 years, Extrel has been committed to providing the highest quality support services for thousands of instruments installed worldwide. Factory trained and certified personnel offer industry-leading support to Extrel customers at every stage of their analytical process.

PREMIUM INSIGHTS – GAIN REAL-TIME INSIGHT INTO YOUR PROCESS

Process Insights' products and solutions deliver innovative and differentiated analysis and measurement solutions and technologies that add high value to our customers and protect the environment.

Our commitment is to deliver smart and affordable innovation that optimizes process, improves safety, and transforms our world.

CENTERS OF EXCELLENCE

PROVIDING PROVEN SOLUTIONS FROM A GLOBAL TECHNOLOGY LEADER

Extrel CMS

575 Epsilon Drive
Pittsburgh, PA 15238
USA
+1 412 963 7530
www.extrel.com
info@extrel.com
support@extrel.com

Process Insights – The Americas

4140 World Houston Parkway
Suite 180
Houston, TX 77032
USA
+1 713 947 9591
info@process-insights.com

Process Insights – EMEA

ATRICOM
Lyoner Strasse 15
60528 Frankfurt
Germany
+49 69 20436910
info@process-insights.com

Process Insights – APAC

Wujiang Economic and Technology
Development Zone
No. 258 Yi He Road, 215200 Suzhou
Jiangsu Province China
+86 400 086 0106
info@process-insights.com

OUR PREMIUM GLOBAL BRANDS

