

Using the Extrel® MAX300-IG™ to Monitor Gasification

Extrel CMS, LLC
Application Note
Gasification
IAG100A

Abstract

Research in the field of biomass gasification is increasingly important as industry continues to find new uses for syngas. At the Energy & Environmental Research Center (EERC) an Extrel MAX300-IG process mass spectrometer was used to monitor the exit stream of a Fluid Bed Gasifier. The quadrupole mass spectrometer provided fast, quantitative analysis of the syngas composition.

Introduction

Over the last several years, concern about the economic and environmental impact of traditional fossil fuel combustion and petrochemicals has led to a search for viable alternatives with gasification emerging as a powerful technique for generating fuel and hydrocarbons. The gasification process makes use of materials such as coal, biomass, and waste to produce synthesis gas, or syngas. Syngas is a combustible mixture of hydrogen, carbon monoxide and carbon dioxide that generally contains a small amount of methane and some trace contaminants. Syngas is used as a fuel source to generate power and heat, or converted into products like hydrogen, for use in fuel cells or fertilizer generation, or liquid fuels via a Fischer-Tropsch reaction.

The MAX300-IG

Gasification and chemical processes utilizing syngas rely upon the ability to obtain information about the composition of the gas stream exiting the reactor. The MAX300-IG is a 7th generation process mass spectrometer capable of performing quantitative analysis on a wide variety of compounds at concentrations ranging from 100% down to 10 ppb. The 19 mm quadrupole mass filter used by the system allows for high analytical repeatability and long term stability.

GASIFICATION

Using the Extrel MAX300-IG to Monitor Gasification

The EERC Test Facility

The MAX300-IG was used to monitor syngas production at the Energy & Environmental Research Center's pilot facility at the University of North Dakota. The system can be configured with either an entrained flow gasifier or a fluid bed gasifier and is used to study, among other things, hydrogen membrane separation, pressure swing absorption, Fischer-Tropsch synthesis, and the effects of coal pretreatment. Pulverized coal or biomass is fed into the gasifier at pressures up to 70 bar, and temperatures that can exceed 1000°C. The flow of the solid fuel feed and gasifier temperature are carefully monitored and controlled along with the flow of steam, oxygen, nitrogen, and recycled syngas (to prevent direct combustion at the oxygen entrance).

Gasifier product is filtered to remove particulates before moving into a series of fixed beds (Fig. 1). Each of the temperature-controlled beds can be loaded for catalyst/sorbent testing or to alter the syngas. Several ports throughout the system allow for gas sampling at each stage and the final product exiting the beds can be routed to test additional equipment or processes.

Gasifier production is monitored by a series of analyzers located on a stream pulled from the second fixed bed.

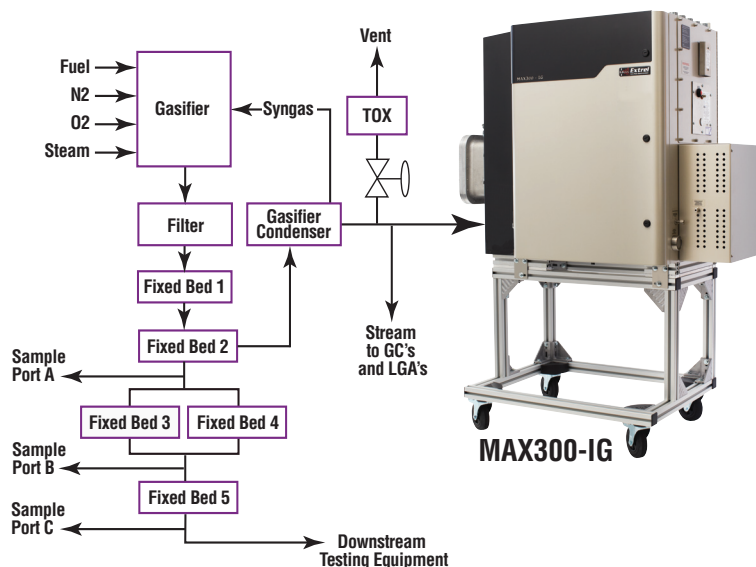

Figure 1. Pilot Gasifier and Syngas Conditioning System

This stream passes through a quench condenser to remove moisture and volatile organics before being analyzed by several gas chromatographs and Raman laser analyzers. The sampling procedure takes one hour, during which the concentration of each component (CO, CO₂, N₂, O₂, H₂, COS, CH₄, H₂O, H₂S) is typically updated between 1 and 3 times every 15 minutes.

MAX300-IG Analysis Results

An analysis method was designed to detect all of the major components in the syngas stream, as well as common sulfur contaminants (Fig. 2).

Each component is measured and recorded in under 0.4 seconds. The total analysis time for this method is < 6 seconds. (continued page 3 of 4)

Fragment Matrix	Sensitivity	Relative Abundance												
		m/z 2	m/z 14	m/z 15	m/z 18	m/z 28	m/z 30	m/z 32	m/z 34	m/z 40	m/z 44	m/z 60		
<input checked="" type="checkbox"/> H2	.179	100												
<input checked="" type="checkbox"/> N2	1.000		10.3513298	0.03508578		99.95059967	0.02310284							
<input checked="" type="checkbox"/> CH4	.639	0.5	15	81		0.09								
<input checked="" type="checkbox"/> H2O	.800				100									
<input checked="" type="checkbox"/> CO	1.170		0.79			100	0.2							
<input checked="" type="checkbox"/> C2H6	1.000	1.2	4.8	6.5		100	23.2							
<input checked="" type="checkbox"/> O2	.980							100	0.4					
<input checked="" type="checkbox"/> H2S	1.000							44	100					
<input checked="" type="checkbox"/> AR	1.500									100				
<input checked="" type="checkbox"/> CO2	1.335					11						100		
<input checked="" type="checkbox"/> COS	2.000					13		60	2.39		8	100		
Background Intensity:		.014469	.000000	.000059	.088273	.006983	.000000	.010989	.000241	.027857	.011222	.000017		
Detector:		Farad	Farad	Farad	Farad	Farad	Farad	Farad	Mult	Farad	Farad	Mult		

Figure 2. The MAX300-IG syngas analysis method containing the list of analytes, detection masses, and calibration values. This image is a screen capture of the Questor5 Software.

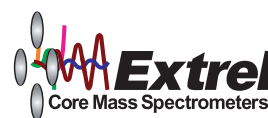

Using the Extrel MAX300-IG to Monitor Gasification

MAX300-IG Analysis Results

The syngas method was run by a MAX300-IG placed online to monitor the gasification of torrefied wood pellets (Fig. 3).

The composition of the syngas varies, cycling approximately every 15 minutes as a result of the automated pulsing of the filter vessel. These events reveal the MAX300-IG's ability to detect rapid changes in the sample stream.

The results for the analysis of a stable syngas mixture demonstrate the analytical stability of the MAX300-IG's quantitative data over 4 hours (Table 1).

Table 1. Average concentrations for the major syngas components recorded during a 4-hour MAX300-IG analysis run on a stable syngas mixture. Each concentration is the average of 1,790 analysis points.

Component	Average Concentration (%)	Standard Deviation
Hydrogen	30.35	0.016
Carbon Monoxide	29.57	0.022
Carbon Dioxide	19.99	0.012
Nitrogen	13.57	0.044
Methane	3.03	0.003
Ethane	0.51	0.002

The measurement of low level sulfur contaminants was performed on the MAX300-IG using the electron multiplier, a part of the dual detector option (Fig. 5). This option extends the detection range of the mass spectrometer to 10 ppb. The detection of increases in sulfur concentrations can be a crucial indicator of catalyst breakdown.

Even at ppm levels, signal stability is quite good, as indicated by the standard deviation of analysis over a relatively steady section of the sulfur trend (Table 2).

Table 2. Average concentrations for the syngas sulfur components recorded on a MAX300-IG electron multiplier. Each concentration is the average of 188 analysis points recorded over 20 minutes.

Component	Average Concentration (ppm)	Standard Deviation
Hydrogen Sulfide	7.9	0.15
Carbonyl Sulfide	8.1	0.20

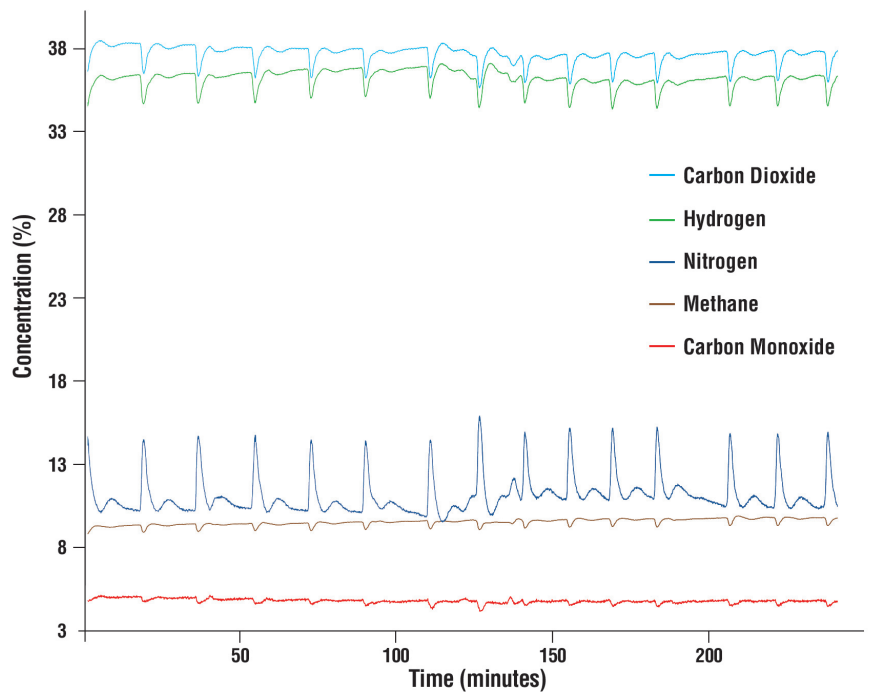

Figure 3. MAX300-IG analysis of the major syngas components. 3,225 samples were recorded over 4 hours of analysis.

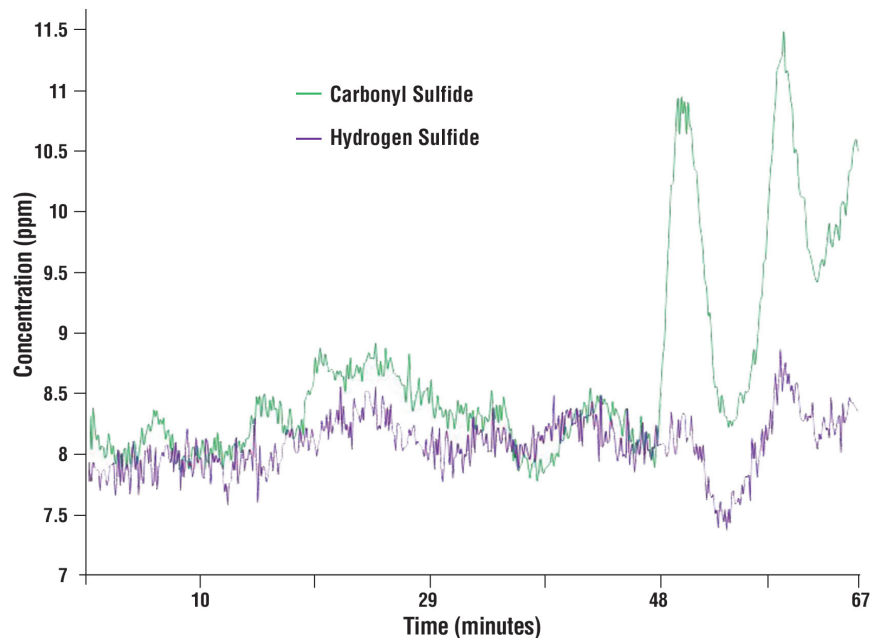
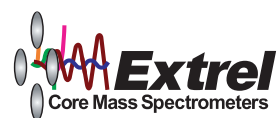

Figure 5. MAX300-IG detection of ppm-level sulfur compounds in syngas. 628 analysis cycles were recorded in the 1 hour 7 minute acquisition period.



Using the Extrel MAX300-IG to Monitor Gasification

Further Applications in Gasification

The MAX300-IG demonstrated that it has the flexibility to quickly characterize and quantify syngas mixtures. It has the sensitivity to detect trace components at ppm levels and below, and the speed to perform each measurement in under 0.4 seconds. The ability to analyze the complete array of syngas components exiting the gasifier, from 100% down to ppm levels, makes the MAX300-IG an instrument capable of replacing complicated analysis systems involving multiple devices and technologies. The speed of the mass spectrometer means that the MAX300-IG can be automated to monitor gas composition at several sample points, delivering a complete set of concentrations at 20 seconds per point.

At the EERC, additional sampling at the ports downstream of the reactor could yield important insight into the operation and efficiency of the fixed beds, or be used to analyze hydrogen membrane separation, or a Fischer-Tropsch product. The speed and flexibility of the MAX300-IG, combined with the capability to run 24/7 in rugged and hazardous industrial environments, make it ideal for monitoring production scale gasification and any associated chemical processes downstream. At large facilities that utilize syngas, like ammonia plants, the MAX300-IG and its predecessors have set the standard for analyzer automation and process control over the last several decades (Fig. 6).

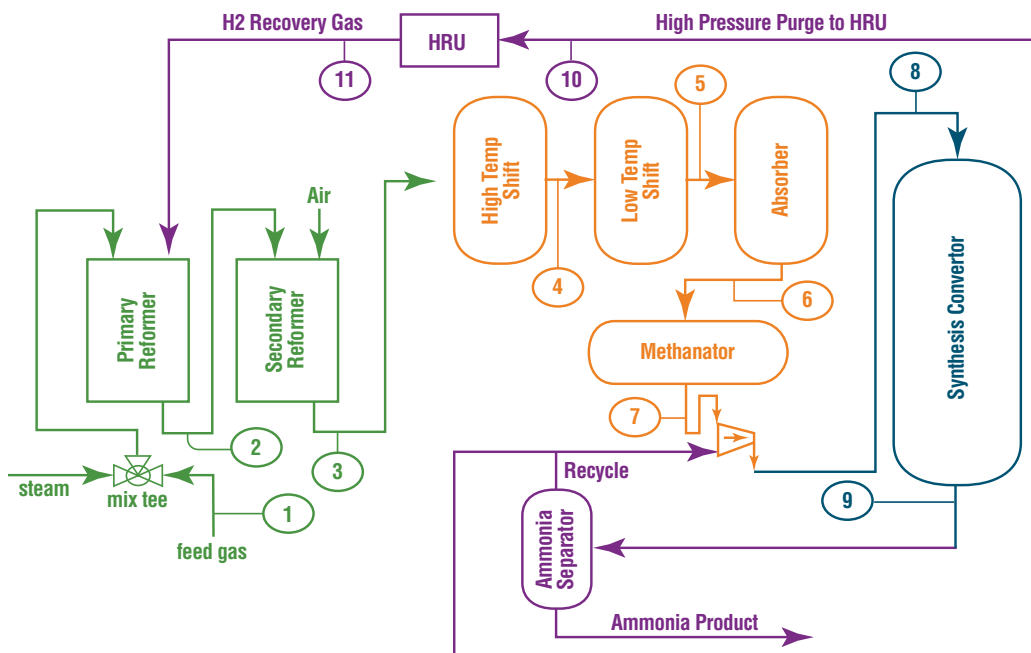

Figure 6. A diagram of the Ammonia Process. Typical analysis points for the process mass spectrometer are indicated at each of the numbered positions. The required syngas can be generated via natural gas reforming or gasification. Total analysis cycle time for 11 sample points is <4 minutes.

Extrel CMS maintains sales and service offices around the world. Please contact us for the office nearest you or visit our website at www.extrel.com. Extrel® is a registered trademark of Extrel CMS, LLC. MAX300-IG is a trademark of Extrel CMS, LLC. © 2013 Extrel CMS, LLC



Extrel CMS, LLC
575 Epsilon Drive – Suite 2
Pittsburgh, PA 15238-2838 USA
TEL: 412-963-7530 • FAX: 412-963-6578

