



SERIES 2500 PERCENT OXYGEN TRANSMITTER



Alpha Omega Instruments Corp.
40 Albion Road, Suite 100
Lincoln, RI 02865
Phone: 401-333-8580
Fax: 401-333-5550
Website: www.aoi-corp.com
Email: salescontact@aoi-corp.com

VERSION 4.0 COPYRIGHT 06/18
ALPHA OMEGA INSTRUMENTS CORP. ALL RIGHTS
RESERVED INCLUDING THE RIGHT TO REPRODUCE
THIS MANUAL, OR ANY PORTION THEREOF, IN ANY FORM.

ALPHA OMEGA INSTRUMENTS CORP.

SERIES 2500 Percent Oxygen Transmitter Loop Powered Instruction Manual

WARRANTY

Alpha Omega Instruments Corp. warrants the products delivered to be free from defects in material and workmanship at the time of delivery to the FOB point specified in the purchase order, its liability under this warranty being limited to repairing or replacing, at Alpha Omega Instruments option, items (excluding the oxygen sensor) which are returned to it **prepaid** within two (2) years from the date of shipment and found to Seller's satisfaction to be defective.

Alpha Omega Instruments one (1) year sensor warranty offers protection for one full year from the date of shipment of the Series 2500 Percent Oxygen Transmitter. Any sensor from a Series 2500 Percent Oxygen Transmitter that fails under normal use must be returned to Seller prepaid and, if such sensor is determined by Seller to be defective, Seller shall provide Buyer a replacement sensor. Buyer must provide the serial number of the transmitter from which the sensor has been removed. If a sensor is found to be defective and a new one issued, the warranty of the replacement sensor (s) is for a period of one year from the date of shipment. At times, it may be necessary to ship a replacement sensor in advance of receiving one returned for warranty claim. In such cases, if the returned sensor is not covered under warranty, the user will be charged the full price of a replacement sensor. **In no event shall Alpha Omega Instruments Corp. be liable for consequential damages. NO PRODUCT IS WARRANTED AS BEING FIT FOR A PARTICULAR PURPOSE AND THERE IS NO WARRANTY OF MERCHANTABILITY.**

This warranty applies only if:

- (i) the items are used solely under the operating conditions and manner recommended in this manual, specifications, or other literature;
- (ii) the items have not been misused or abused in any manner or repairs attempted thereon;
- (iii) written notice of the failure within the warranty period is forwarded to Alpha Omega Instruments Corp. and, the directions received for properly identifying items returned under warranty are followed;
- (iv) the return notice authorizes Alpha Omega Instruments Corp. to examine and disassemble returned products to the extent the Company deems necessary to ascertain the cause of failure.

The warranties stated herein are exclusive. THERE ARE NO OTHER WARRANTIES, EITHER EXPRESSED OR IMPLIED, BEYOND THOSE SET FORTH HEREIN, and Alpha Omega Instruments Corp. does not assume any other obligation or liability in connection with the sale or use of said products.

Disclaimer of Warranty

Alpha Omega Instruments Corp. makes no representation or warranties, either expressed or implied, by or with respect to anything in this manual, including, but not limited to, implied warranties of merchantability or fitness for a particular purpose. In no event will Alpha Omega Instruments Corp. be liable for any damages, whether direct or indirect, special, consequential, or incidental arising from the use of this manual. Some states in the USA do not allow the exclusion of incidental or consequential damages. Alpha Omega Instruments Corp. also reserves the right to make any changes to improve the performance of its products at any time and without notice.

ALPHA OMEGA INSTRUMENTS CORP.
SERIES 2500 Percent Oxygen Transmitter Loop Powered Instruction Manual

TABLE OF CONTENTS

		PAGE
	WARRANTY	
SECTION 1.0	SPECIFICATIONS	1
SECTION 2.0	SYSTEM DESCRIPTION	2
SECTION 3.0	INSTALLATION PROCEDURES	3
SECTION 4.0	OPERATING PROCEDURES	4
SECTION 5.0	CALIBRATION PROCEDURES	5
SECTION 6.0	REPLACEMENT OF OXYGEN SENSOR	7
FIGURE 1.0	SERIES 2500 WIRING DIAGRAM FOR 4-20 mADC OUTPUT	8
FIGURE 2.0	EXPANDED VIEW OF SPAN AND ZERO ADJUSTMENTS	9
FIGURE 3.0	OUTLINE DRAWING OF OPTIONAL NEMA 7 ENCLOSURE	10
APPENDIX A	MSDS FOR THE 2SEN OXYGEN SENSOR	11

ALPHA OMEGA INSTRUMENTS CORP.
SERIES 2500 Percent Oxygen Transmitter Loop Powered Instruction Manual

Section 1.0
Specifications

PERFORMANCE

Measurement Ranges in Percent
0-2, 0-5, 0-10, 0-25, 0-50, and 0-100

Accuracy¹:	+ 1% of full scale.
Linearity:	+ 1% of full scale.
Response Time:	90% of full scale in less than 20 seconds (typical).
Sensor Type:	Long-life Electrochemical Sensor.
Temperature Compensation:	Standard.
Operating Temperature Range:	40° to 104°F (5° to 40°C)
Warranty:	Two years for the electronics and one year for the sensor.

ELECTRICAL

Input power 14-32 VDC

Loop Resistance: 600 ohms @ 24 VDC (consult factory for other resistance values)

SAMPLE GAS CHARACTERISTICS

Sample Flow Rate: 1.0 to 2.0 standard cubic feet per hour (SCFH)
0.5 to 1.0 liters/ minute (LPM)

Sample Gas Pressure Limits: 0.1 to 1.5 psig (0.007 to 0.1 kg/cm²).

CONSTRUCTION

Enclosure: Polycarbonate, rated NEMA 4X (IP66) without optional equipment.

NEMA 7 (explosion proof) optional.

Dimensions: 6.5 in. (165.1 mm) height
7.0 in. (177.8 mm) width
3.9 in. (99.06 mm) depth.
Note: All dimensions are without optional equipment

Gas Connections: Quick connect 1/4" OD for plastic tubing or stainless steel compression fittings for installations with metal sample lines.

¹ Stated at constant temperature and pressure.

ALPHA OMEGA INSTRUMENTS CORP.
SERIES 2500 Percent Oxygen Transmitter Loop Powered Instruction Manual

SECTION 2.0
SYSTEM DESCRIPTION

General Description

The Series 2500 Percent Oxygen Transmitter is an Loop powered blind transmitter designed to provide accurate and dependable percent oxygen measurements in a variety of gases. The transmitter enclosure is made from durable polycarbonate and is rated watertight (NEMA 4) or optionally for use in Class 1, Groups B, C, D, Div. 1 areas (NEMA 7).

The instrument is powered from 14-32 Volts DC, and provides a 4-20 mADC output that can be sent to a datalogger, recorder, PLC, DCS, etc. Options include a pressure regulator, flow meter, and an in-line filter for sample gases that contain particulate matter.

Ambient Temperature Electrochemical Sensor with EES

The Series 2500 Percent Oxygen Transmitter features an extended life oxygen sensor with EES (enhanced electrolyte system) a weak acid electrolyte system. The weak acid electrolyte system retards passivation of the sensor anode by allowing the products of oxidation to dissolve in the acid electrolyte. In effect, the sensor is renewed continuously as the weak acid electrolyte tolerates over 20 times the lead oxide (PbO) than potassium hydroxide (KOH) based sensors. The result is a sensor with a greatly extended useful life.

The extended life sensor is a lead-oxygen battery comprised of a lead anode, and gold cathode, and a weak acid electrolyte. A gold electrode is bonded onto a non-porous Teflon (FEP) membrane. A small amount of oxygen permeating through the membrane is reduced electrochemically at the gold electrode. A resistor and a thermistor (for temperature compensation) are connected between the cathode and anode. As a result, the lead-oxygen battery is always discharged.

Current flowing through the resistor and thermistor is proportional to the oxygen concentration of the gas in contact with the Teflon membrane. By measuring the voltage between the between the resistor and the thermistor, oxygen concentration can be accurately determined. The two electrode reactions are depicted below:

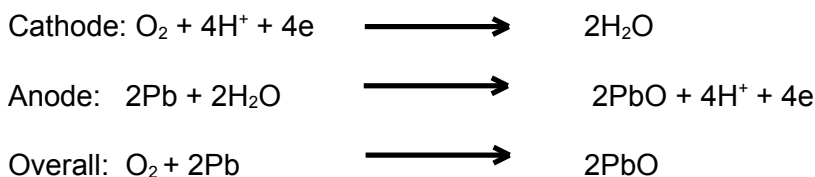

If PbO generated at the anode remains on the anode, the anode's potential will change and the output voltage of the sensor would become extremely low. However, in actuality the surface of the lead anode is continuously renewed because PbO is dissolved back into the electrolyte. There is a maximum solubility limit of PbO in the weak acid electrolyte. As a result, when the electrolyte becomes saturated with PbO, the sensitivity of the sensor will begin to drop signaling time for replacement of the sensor. When the extended life oxygen sensor is used in applications where carbon dioxide (CO₂) is present, the weak acid electrolyte provides protection from a rapid deterioration in sensor life due to CO₂ poisoning. Sensors that use potassium hydroxide electrolyte are adversely affected by CO₂. This is not the case with Alpha Omega Instruments extended life oxygen sensor.

ALPHA OMEGA INSTRUMENTS CORP.
SERIES 2500 Percent Oxygen Transmitter Loop Powered Instruction Manual

SECTION 3.0
INSTALLATION PROCEDURES

Unpacking the Instrument

Upon opening the shipping container, carefully unpack the transmitter to check if the outer surfaces have been damaged. If so, report the findings immediately to Alpha Omega Instruments who will provide further instructions. If there is no apparent damage, check the contents to ensure all items were shipped. In some cases, items may be back-ordered.



All damage and shortage claims must be made known to Alpha Omega Instruments within 10 days after receipt of shipment

There are four screws securing the cover of the Series 2500 Trace Oxygen Transmitter. Removing these screws allows access to the inside of the enclosure. The cover should be removed and the interior of the enclosure checked to ensure that no components have been loosened or dislodged. **If there are loose or dislodged components, notify the factory for further instructions.** If all is found to be satisfactory, the installation procedure can begin.

For Series 2500's supplied with Explosion Proof (NEMA 7) enclosures, to gain access to the inside of the instrument, the cast aluminum cover (cylindrical device) must be removed by spinning it off the base of the instrument in a counterclockwise fashion. **If there are loose or dislodged components, notify the factory for further instructions.** If all is found to be satisfactory, the installation procedure can begin.

Electrical Installation

The Series 2500 Trace Oxygen Transmitter is powered by a user supplied power supply, and as such, there is no AC power cord. Power to the Series 2500 should be 14-32 VDC @ 4-20 mADC. Consideration should be given to the resistance of the cable in relation to the DC power used. The following formula should be used to determine maximum loop resistance:

$$R_L \text{ (K ohms max.)} = \frac{\text{Input VDC}-12}{20}$$

Wiring to the Analog Output

The Series 2500 Trace Oxygen Transmitter is a true blind transmitter that is, it has no power source of its own and operates from loop power supplied by an external power supply. The Series 2500 will adjust the load current on the external power supply in such a manner that the loop current that flows will reflect the level of oxygen being measured over the milliamp current range of 4-20 mADC. To wire to the 4-20 mADC output, wire to terminals J8 (+) and J9 (-) (Return). Please refer to Figure 1.0.

ALPHA OMEGA INSTRUMENTS CORP.
SERIES 2500 Percent Oxygen Transmitter Loop Powered Instruction Manual

SECTION 4.0
OPERATING PROCEDURES

Gas System Pressure Limits

For sample gases and/or calibration gases that are under pressure, it is imperative that the sample gas pressure to the sensor be kept to under **1 pound per square inch**. If it is expected to be in excess of 1.0 psig a pressure regulator should be used.

Range Identification

The Series 2500 Percent Oxygen Transmitter is available in six (6) different ranges. To identify the specific range of the transmitter in question, please refer to the original purchase order document or invoice from Alpha Omega Instruments. In it, you will find a model number starting with the number 2500. The letter immediately following "2500" is the range identifier. The various ranges, with their associated identifier, are as follows:

<u>Range (%)</u>	<u>Identifier</u>
0-2	A
0-5	B
0-10	C
0-25	D
0-50	E
0-100	F

Sample Connections

The sample flow connections to the Series 2500 Percent Oxygen Transmitter are quick connect fittings to be used with 1/4" OD flex tubing such as polypropylene, nylon, etc. An optional 1/4" gas compression fitting on the gas inlet to the sensor is available.

Electrical Output

The Series 2500 Percent Oxygen Transmitter produces an analog output of 4-20 mADC that can be used with a recorder, datalogger, etc.

Transmitter Storage

When the Series 2500 is not in use, it should be stored indoors within a temperature range of 40° to 104° F.

ALPHA OMEGA INSTRUMENTS CORP.
SERIES 2500 Percent Oxygen Transmitter Loop Powered Instruction Manual

SECTION 5.0
CALIBRATION PROCEDURES

Routine Span Gas Calibration Checks

The Series 2500 Percent Oxygen Transmitter has been calibrated at the factory prior to shipment. Alpha Omega Instruments percent oxygen sensors feature high accuracy and excellent long term stability characteristics. As a result, routine maintenance is kept to a minimum. As is the case with all high precision gas measuring instruments, it is advisable to periodically check the overall system calibration. The frequency of these checks is often determined by in-house calibration protocols. If none exists, Alpha Omega Instruments Corp. recommends a calibration check be made once every 3-4 months.

Calibration Gas

The oxygen sensor used in the Series 2500 Percent Oxygen Transmitter has a linear output. As a result, it can be calibrated using a single calibration gas as long as the test is performed accurately. The calibration gas should contain a defined concentration of oxygen with a balance of nitrogen (N₂). For transmitters with a full scale ranges of 25% or greater, use of clean ambient air for calibration is recommended. The actual concentration of oxygen should be selected based on the range of the transmitter. Alpha Omega Instruments recommendation is to obtain a calibration gas that has a concentration of oxygen somewhere between 60-90% of full scale. For instance, if the transmitter has a measuring range of 0-10 percent, a calibration gas containing 6-9 percent oxygen/balance nitrogen should be used.

Procedure for Checking Calibration

1. If air is **not** going to be used for calibration, select a cylinder of calibration gas as described above.
2. When selecting a pressure regulator to use with the cylinder gas, it is advisable to use a two-stage regulator with the second stage capable of delivering a gas sample at a pressure of under 1.0 psig.
3. In addition to the selection of the pressure regulator, use of good quality rigid plastic tubing is acceptable.
4. Begin flowing the calibration gas to the transmitter by connecting the gas to the inlet of the sensor. If no filter, or flow meters are attached to the sensor housing, the calibration gas can be connected to either of the two gas fittings on the sensor housing. The flow of calibration gas should be set to 1 liter per minute. If the optional flow meter has not been purchased, it is advisable to secure one for use during calibration. Begin monitoring the 4-20 mADC output waiting until a stable reading has been established.
5. Once the oxygen reading has stabilized, check the system for gas leaks. This is best done when step 4 has been completed. An easy method of determining the leak integrity of the system is to vary the flow rate of the calibration gas. If increasing the flow rate from 1 liter per minute to 2 liters causes an appreciable drop (>10% of reading) in the oxygen reading, there is a good chance that somewhere between the gas source and inlet to the sensor there is a leak. Check all gas fittings, connections, etc. If the integrity of the sample delivery system appears to be good, move on to step 6.

ALPHA OMEGA INSTRUMENTS CORP.
SERIES 2500 Percent Oxygen Transmitter Loop Powered Instruction Manual

6. The milliamp current output controlled by the transmitter should reflect the oxygen concentration of the calibration gas. A readout device must be connected to the 4-20 mADC output to provide a reading of the oxygen concentration. A volt meter is usually very handy for this purpose as it can be placed close to the transmitter. If for example, a transmitter with a full scale range of 0-10% is being calibrated with a 5% calibration gas, an output of 12 mADC should be obtained. The general form of the equation for determining the percent oxygen concentration reading from the reading in milliamps is:

$$\text{mADC: \%} = (\text{mADC} - 4) \times \text{FSV}/16$$

where *FSV* is the Full Scale Value for the oxygen range selected. In the example given above, $\% = (12 - 4) \times 10/16 = 5\%$.

7. If the oxygen value obtained from the 4-20 mADC output differs from that which is expected from the calibration gas, a span adjustment should be made. To accomplish this, locate the gain adjustment potentiometer (R12) on the board labeled "CAL". Using a small blade screw drive, adjust R12 so the oxygen value reflected in the 4-20 mADC output is equal to the oxygen value represented by the calibration gas. Once step 7 has been completed, replace the cover of the instrument and resume normal operation.

Zero Adjustment

Alpha Omega Instrument's Percent Oxygen Sensor is specific for oxygen. When there is no oxygen present, the output from the sensor is zero. This coupled with the inherent linear characteristics of the sensor allow the user to use a single point calibration as means of calibrating the system. Zeroing the instrument is typically not required.

However, if the user wants to check zero, a high purity supply of nitrogen (<1 ppm O²) should be used as zero gas. Process the zero gas through the transmitter for approximately one hours time. The length of time will be predicated on factors such as length of tubing, tubing material, flow rate and long term exposure to high levels of oxygen. Once the zero reading has stabilized, if the oxygen value obtained from the 4-20 mADC output is not zero (4 mADC) a zero offset adjustment should be made. To do this, refer to Figure 2 and locate the zero adjustment (R18). Adjust this potentiometer so the oxygen value reflected in the 4-20 mADC output is at 4 mADC. Once accomplished, the transmitter can now be placed back in service.

ALPHA OMEGA INSTRUMENTS CORP.
SERIES 2500 Percent Oxygen Transmitter Loop Powered Instruction Manual

SECTION 6.0
REPLACEMENT OF THE OXYGEN SENSOR

Alpha Omega Instruments oxygen sensor is designed to operate for prolonged periods of time without needing replacement. However, in time the sensor's output will drop to a level where replacement becomes the prudent course of action. A good indication of this is a marked increase in calibration frequency. When this happens, a replacement sensor should be ordered directly from the factory. The part number for a replacement sensor is **2SEN**. *When ordering a replacement sensor, please include the serial number of the instrument.*

To install a new sensor follow the directions below:

- 1.0 Remove all power from the instrument.
- 2.0 Locate the brass sensor housing located under the transmitter (or inside the NEMA 7 enclosure).
- 3.0 Remove the cover from the transmitter by loosening the four screws at each of the four corners of the cover.
- 4.0 Locate the oxygen sensor inside the transmitter and remove the two-wire connector.
- 5.0 Turn the sensor counterclockwise to unscrew it from its holder. Discard the old sensor (see precautionary note below) and install the replacement sensor being careful not to over-tighten the sensor. The sensor has an "O" ring seal that when **finger tightened**, will provide the required seal. Reattach the electrical connector and reinstall the cover.



THE SENSOR CONTAINS A SMALL AMOUNT OF WEAK ACID.
WHEN DISCARDING SPENT SENSORS, CARE SHOULD BE GIVEN
NOT TO PUNCTURE THE SENSOR OR TO TAKE IT APART.
DISPOSE OF THE SPENT SENSOR ACCORDING TO LOCAL,
COUNTY, OR STATE GUIDELINES.

- 6.0 Apply power and calibrate according to **Section 5.0**.

ALPHA OMEGA INSTRUMENTS CORP.
 SERIES 2500 Percent Oxygen Transmitter Loop Powered Instruction Manual

SERIES 2500 PERCENT OXYGEN TRANSMITTER
 WIRING DIAGRAM

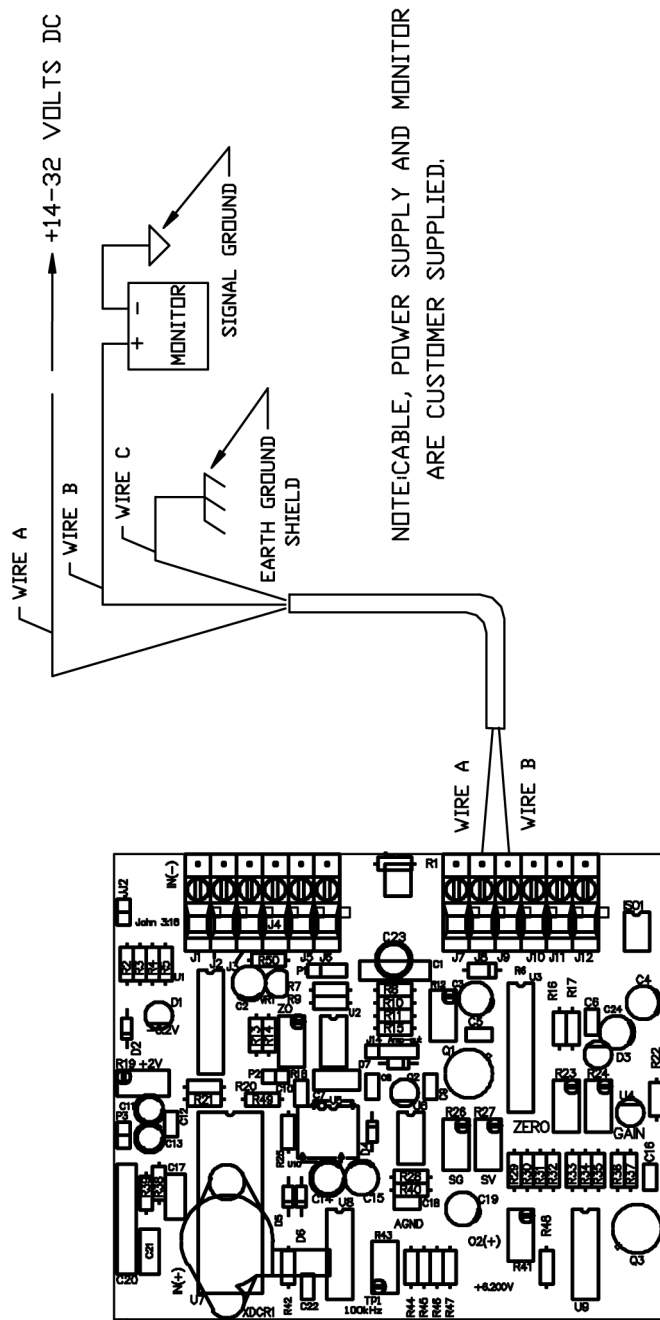
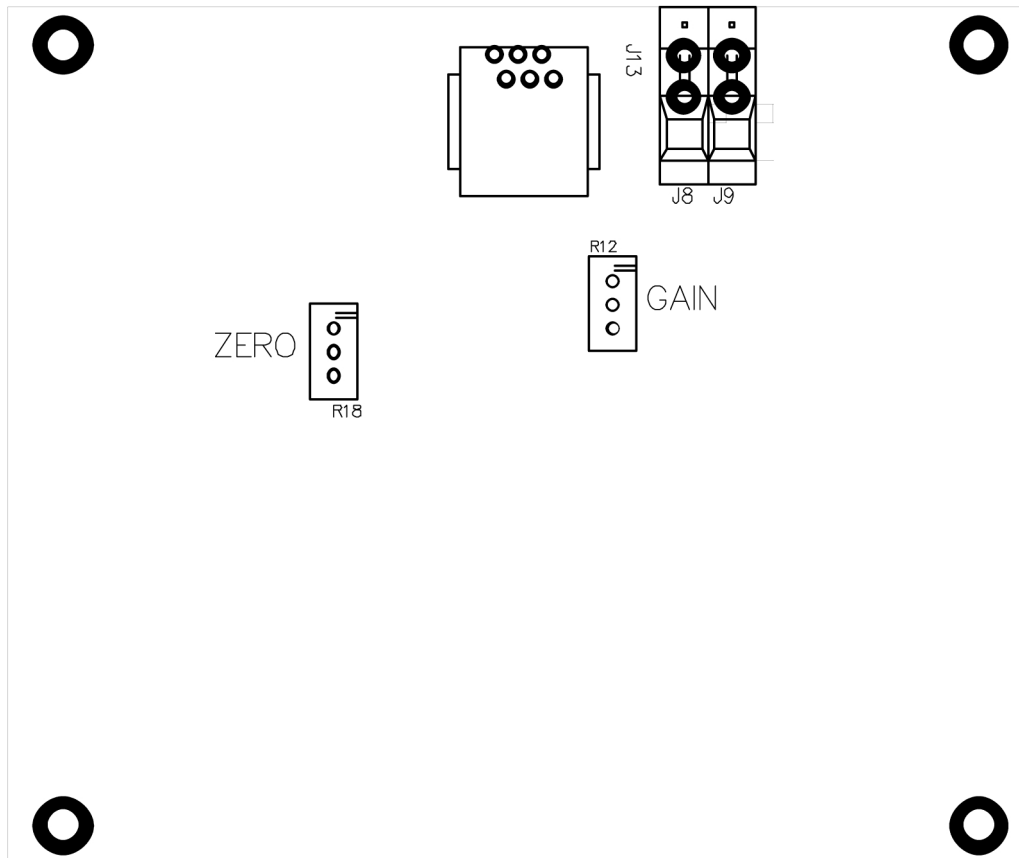

FIGURE 1.0

ALPHA OMEGA INSTRUMENTS CORP.
SERIES 2500 Percent Oxygen Transmitter Loop Powered Instruction Manual



Expanded View of the Span and Zero Adjustments.

FIGURE 2.0

ALPHA OMEGA INSTRUMENTS CORP.
SERIES 2500 Percent Oxygen Transmitter Loop Powered Instruction Manual

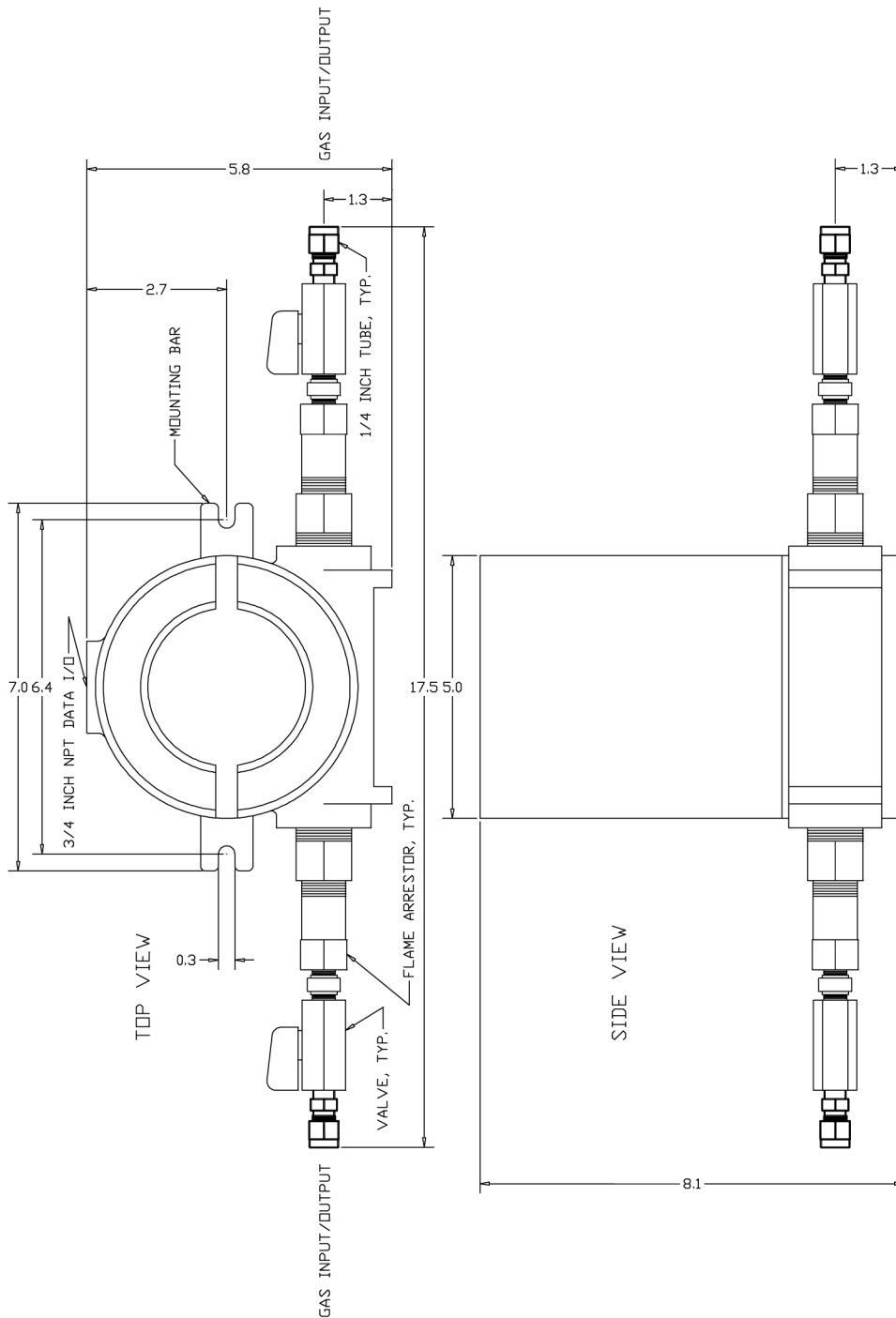

OUTLINE DRAWING OF OPTIONAL NEMA 7 ENCLOSURE
 (please note that the valves are optional)

FIGURE 3.0

Appendix A

Material Safety Data Sheet for the 2SEN Oxygen Sensor

SECTION I - PRODUCT IDENTIFICATION

Manufacturer's Name: Alpha Omega Instruments Corp
Address 40 Albion Road, Suite 100
Telephone 401-333-8580
Date Prepared September 3, 1998
Date Revised April 12, 2001
Trade Name 2SEN and 1SEN
Description Weak acidic solution encapsulated in plastic housing.

SECTION II - HAZARDOUS INGREDIENTS OF SOLUTION

Lead Acetate, Trihydrate CAS # 6080-56-4
OSHA/PEL 0.05 mg/m3
ACGIH/TLV 0.15 mg/m3

TLV and PEL are for lead, inorganic dusts and fumes, as Pb

Note: Lead has been reported as causing cancer in laboratory animals, exercise due care.

Acetic Acid, Glacial CAS # 64-19-7
OSHA/PEL 10 PPM
ACGIH/TLV 10 PPM

NOTE: TLV and PEL are for concentrated (90% - 100%) Acetic Acid, actual solution is less than 50%.

Lead CAS # 7439-92-1
OSHA/PEL 0.03mg/m3

SECTION III - PHYSICAL & CHEMICAL CHARACTERISTICS

Boiling Point: Not Available **Specific Gravity:** Not Available

Vapor Pressure: Not Available **Vapor Density:** Not Available

Evaporation Rate: Not Available **Physical State:** Liquid

Melting Point: Not Available **pH:** 3.5 - 7.0 **Flash Point:** > 100 degrees C

Appearance & Odor: Colorless Liquid: Vinegar like odor

Extinguisher Media: Use water spray, alcohol foam, dry chemical or carbon dioxide

Special Fire Fighting Procedures: Respiratory protection should be used to avoid breathing fumes.

Unusual Fire & Explosion Hazards:

Lead acetate decomposes at boiling point and toxic gases are produced. Acetic acid vapors may flow along surfaces to distant ignition sources and flash back. Closed containers exposed to heat may explode.

SECTION IV - REACTIVITY DATA OF SOLUTION

Stability Stable

Appendix A
Material Safety Data Sheet for the 2SEN Oxygen Sensor

Hazardous Polymerization:	Will not occur
Conditions to Avoid:	Heat, flame, other sources of ignition
Incompatibles:	Strong acids, strong bases, strong oxidizing agents.
Decomposition Products:	Lead fumes, carbon monoxide, carbon dioxide.

SECTION V - HEALTH HAZARD DATA OF SOLUTION

Lead Acetate Component	Data is for lead, inorganic dusts and fumes as Pb
(TLV/TWA):	0.15 mg/m3
STEL:	Not Established
PEL:	0.05 mg/m3
Toxicity:	Intraperitoneal Rate LD50 for Lead Acetate Trihydrate is 200 mg/Kg
Carcinogenicity:	This substance is listed as a NTP anticipated human carcinogen and an IARC animal carcinogen.
Reproductive Effects:	None identified
Effects of Overexposure:	
INHALATION:	Tightness and pain in chest, coughing, difficult breathing.
SKIN CONTACT:	Irritation.
EYE CONTACT:	Irritation.
SKIN ABSORPTION:	May be harmful.
INGESTION:	Is harmful and may be fatal, headache, nausea, vomiting, dizziness, gastrointestinal irritation.
CHRONIC EFFECTS:	Anemia, kidney damage, blurred vision, lead build-up in the central nervous system.
Target Organs:	GI tract, central nervous system, kidneys, blood, gingival tissue.
Medical Conditions Generally Aggravated by Exposure:	None identified.
Primary Routes of Entry:	Ingestion, inhalation, eye contact, skin contact, absorption.
Emergency and First Aid Procedures:	
INGESTION:	CALL A PHYSICIAN. Give large amounts of water.
INHALATION:	If inhaled, remove to fresh air.
SKIN CONTACT:	In case of contact, flush with water for at least 15 minutes.
EYE CONTACT:	In case of contact, flush with water for at least 15 minutes.

SECTION V - HEALTH HAZARD DATA OF SOLUTION cont'd

Acetic Acid	Data is for concentrated acid.
Threshold Limit value (TLV/TWA)	25 mg/m3
Short term exposure limit (STEL)	37 mg/m3
Permissible exposure limit (PEL)	25 mg/m3

Appendix A

Material Safety Data Sheet for the 2SEN Oxygen Sensor

Toxicity:

Oral rate LD50 for acetic acid:	3310 mg/kg
Intravenous mouse LD50 for acetic acid:	525 mg/kg
Skin rabbit LD50 for acetic acid:	1060 mg/kg
Inhalation mouse LD50 for acetic acid:	5620 mg/kg
Carcinogenicity NTP:	No
IARC	No
Z List:	No
OSHA Reg:	No

Carcinogenicity: None identified

Reproductive Effects: None identified

Effects of Overexposure:

INHALATION:	Severe irritation or burns of respiratory system
SKIN CONTACT:	Severe burns, may cause dermatitis
EYE CONTACT:	Severe burns, permanent eye damage.
SKIN ABSORPTION:	None identified
INGESTION:	Burns to mouth and throat, nausea, vomiting, gastrointestinal irritation, diarrhea, shock, may be fatal
CHRONIC EFFECTS:	Lung damage, teeth damage

Target Organs: Respiratory system, eyes, skin, teeth, lungs.

Medical Conditions Generally Aggravated by Exposure: Respiratory system disease, skin disorders.

Primary Routes of Entry: Inhalation, ingestion, skin contact, eye contact.

Emergency and First Aid Procedures:

INGESTION:	CALL A PHYSICIAN. Give large amounts of water.
INHALATION:	If inhaled, remove to fresh air.
SKIN CONTACT:	Immediately flush skin with plenty of water for at least 15 minutes.
EYE CONTACT:	Immediately flush with plenty of water for at least 15 minutes.

SECTION VI - SPILL AND DISPOSAL PROCEDURES

NOTE: The sensors are sealed, and under normal circumstances, the contents of the sensors do not present a health hazard. The following information is given as a guide in the event that a cell leaks.

Steps to be taken in the event of a spill or discharge:

- Wear respiratory protection and full protective clothing
- Neutralize spill with soda ash or lime
- Carefully place material into clean, dry container and cover.

Appendix A

Material Safety Data Sheet for the 2SEN Oxygen Sensor

Flush spill area with water.

Disposal Procedure:

Dispose in accordance with all applicable federal, state and local environmental regulations, with regards to lead or lead acetate.

EPA Hazardous Waste Numbers:

Lead	D008
Lead Acetate	U144 (Toxic Waste)
Acetic Acid, Glacial	D001, D002 (Ignitable, Waste)

SECTION VII - ENGINEERING AND WORK PRACTICES CONTROLS

VENTILATION: Use general or local exhaust ventilation to meet TLV requirements.

RESPIRATORY PROTECTION: Respiratory protection required if airborne concentration exceeds TLV.

EYE/SKIN PROTECTION: Safety goggles, uniform, apron, neoprene gloves are recommended.

Protective measures during cell replacement:

Before opening the packaging containing the sensor cell, check the sensor cell for leakage. If the sensor cell leaks, do not open the container. If there is liquid around the cell while in the instrument, use the protection listed above in this section.

SECTION VIII - STORAGE AND HANDLING PRECAUTIONS

Storage Requirements: Store in a cool, well-ventilated area.

NOTE: The above data is based on tests and experience which Alpha Omega Instruments, Inc. believes reliable and are supplied for information purposes only. Alpha Omega Instruments Corp. disclaims any liability for damage or injury which results for the use of the data and nothing contained there in shall constitute a guarantee, warranty (including warranty of merchant ability) or representation (including freedom from patent liability) by Alpha Omega Instruments Corp. with respect to the data, the product described, or their use for any specific purpose, even if that purpose is known to Alpha Omega Instruments Corp.